



year 2019 rev.0

# RIL160 Level transmitter

## User's Manual

## 1. Safety Instructions

- To avoid operator hazards and damages of the device, the following instructions have to be worked out by qualified technical personnel.
- By non-observance of the operating manual, inappropriate use, modification or damage, no liability is assumed and warranty claims will be excluded.
- Permissible media are liquids (no solids and frozen media), specified in the data sheet. In addition it has to be ensured, that this medium is compatible with the media wetted parts.
- Install the device only when depressurized and currentless.
- Handle this high-sensitive electronic precision measuring device with care, both in packed and unpacked condition.
- There is a plastic tube (the reference tube) in the special transmitter cables to connect the atmosphere. In installation and operation, connect the reference tube with the atmosphere unobstructed and prevent mud and sand stopping up the reference tube, especially water or other liquid. Otherwise, the transmitter would be destroyed.

## 2. General information

RIL160 series level transmitters make use of high-performance silicon piezoresistive pressure sensor as sensing element. The transmitter measures the vertical depth of a column of liquid and converts this depth into the standard amplified analog signals.

RIL160 series level transmitters feature a fully-sealed structure and are made from 304 stainless steel. The cable used in these transmitters is anti-oil, water-proof and electromagnetic effect shielded PE&PUR cable with vent hose for atmospheric pressure in. The environment protection grade of these transmitter is IP68.

RIL160 is of integrated structure with sensing element and signal conditioning circuit located and sealed in the probe housing. In application the transmitter is merged in the measured liquid. No external adjustment or calibration is needed.

### Applications

- Level measurement

### 3. Performance Specifications

Parameter	Value		
<b>General</b>			
Pressure Range	0.5,...,200mH2O		
Overpressure	1.5xFS		
<b>Environmental</b>			
Operating Temp. Range	0 to +70°C		
Compensated Temp. Range	0 to +60°C		
Storage Temp. Range	-40 to +125°C		
Vibration	10g(20 to 2000Hz)		
Shock	100g(10ms)		
Cycles	10x10 <sup>6</sup> cycles		
<b>Electrical @25°C(77°F)</b>			
Output Signal	4...20mA		
Power Supply(Vs)	12....36Vdc		
Load Resistance	<(Vs-12)/0.02A		
Insulation Resistance	100MΩ@50Vdc		
<b>Physical Specifications</b>			
Housing	304 stainless steel		
Diaphragm	316L stainless steel		
Seal Ring	Viton or NBR		
Oil Filling	Silicone oil		
Protection	IP68		
Parameter	Min.	Typical	Max.
Accuracy[%FSO]	0.1	0.25	0.5
Temp Coeff - Zero[%FSO]		±0.75	±1.5
Temp Coeff - Span[%FSO]		±0.75	±1.5
Long-Term Stability[%FSO/year]		±0.2	±0.3

## 5. Mechanical Installation

### 5.1 Check before Installation

Attention before transmitter installation:

- The static pressure produced by the liquid in the installation place may exceed the transmitter FS range.
- The measuring liquid is compatible with the transmitter construction material or not.
- The measuring liquid may stop up the holes on the protection cap or not.

### 5.2 Installation Methods

- The installation direction of transmitter is vertical down.
- In the water flowing condition, the acted surface should be parallel with the water flowing direction.

#### 5.2.1 Installation in the Static Water

- The installation method in the static water indicated as chart 5-1.

To prevent shaking or destroying the transmitter when pumping, the transmitter should be put away from the liquid resource. Otherwise it should be installed to see chart 5-2, protected by steel tube.

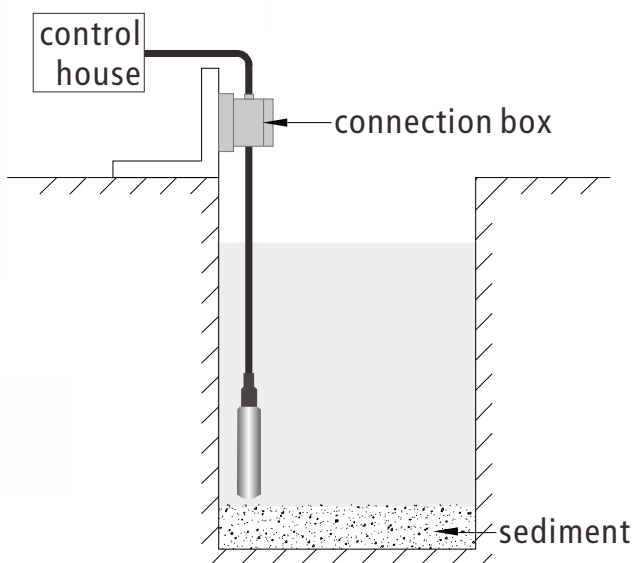

Chart 5-1

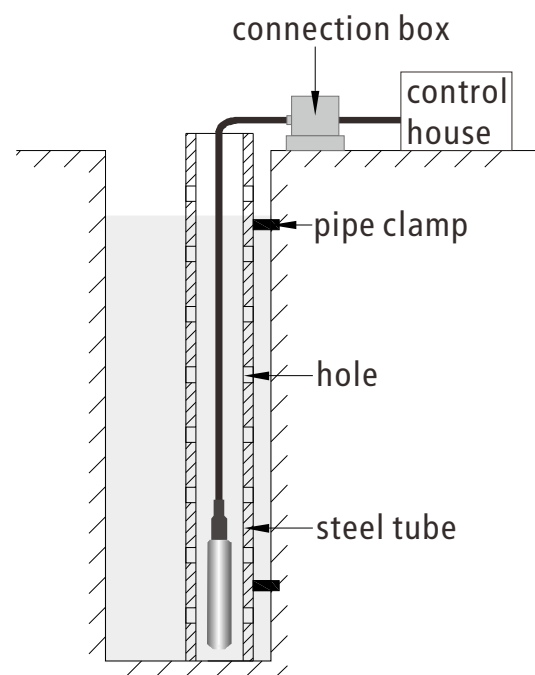

Chart 5-2

### 5.2.2 Installation in Flowing Water (e.g. river channel, reservoir area)

The water-calming equipments are required.

- a. Method one: Insert a steel tube in the water channel (chart 5-3).  
The steel tube wall should be thicker, and several holes should be made on different heights of the tube to damp waves and clear the water pressure influence.

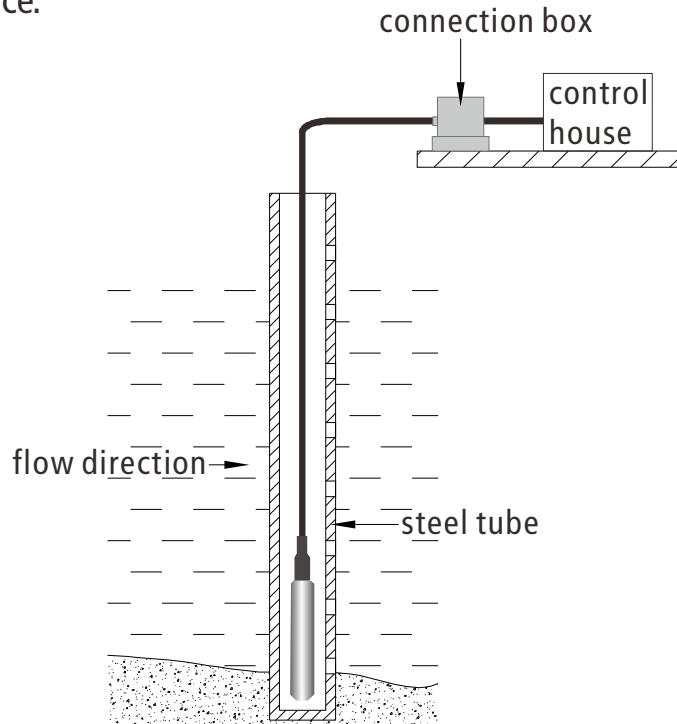

Chart 5-3

- b. Method two: Superficial burying is better in the sand and stone channel (chart 5-4). This method not only can clear water flowing pressure and wave influence, but also can filter the sand and mud.

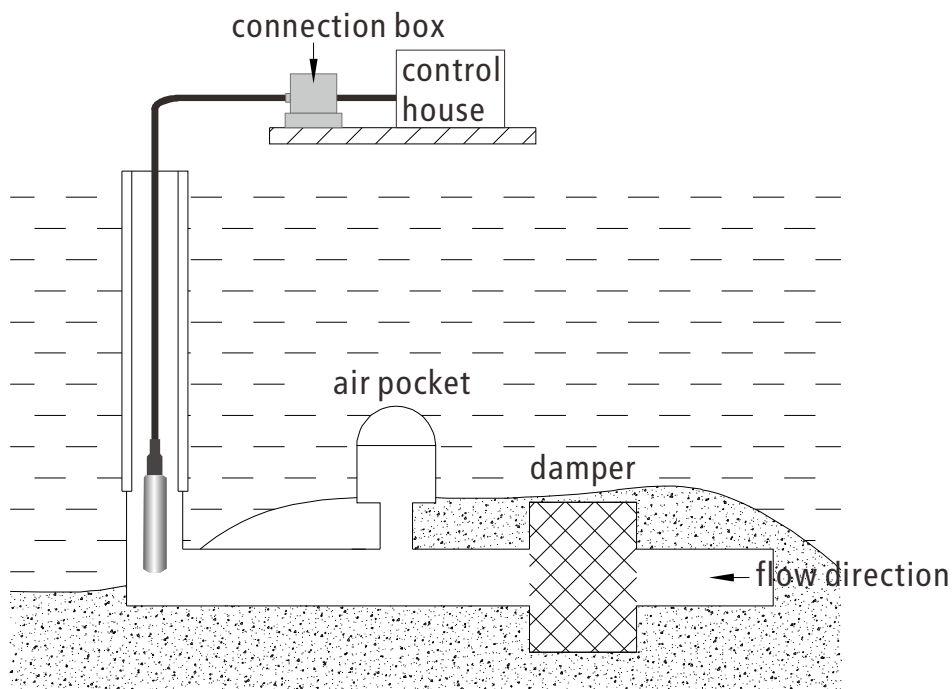
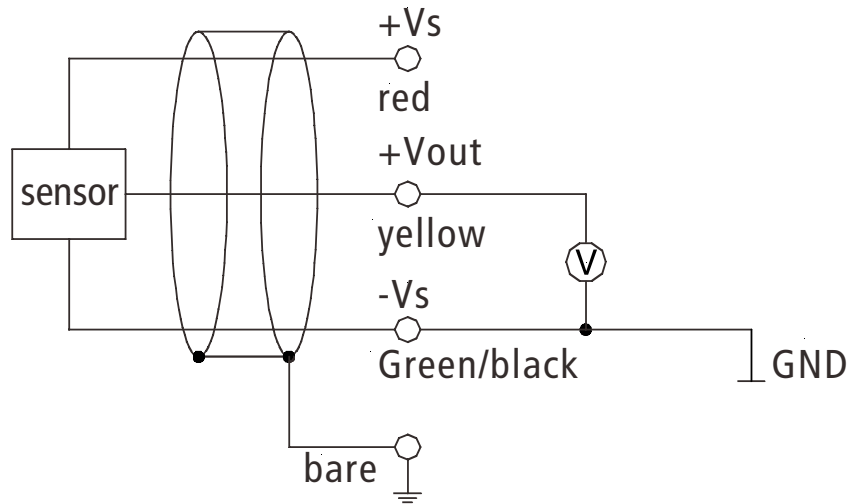

Chart 5-4

## 6. Electrical connection

### 0...10 V, 1...5V output



### 0...20mA output

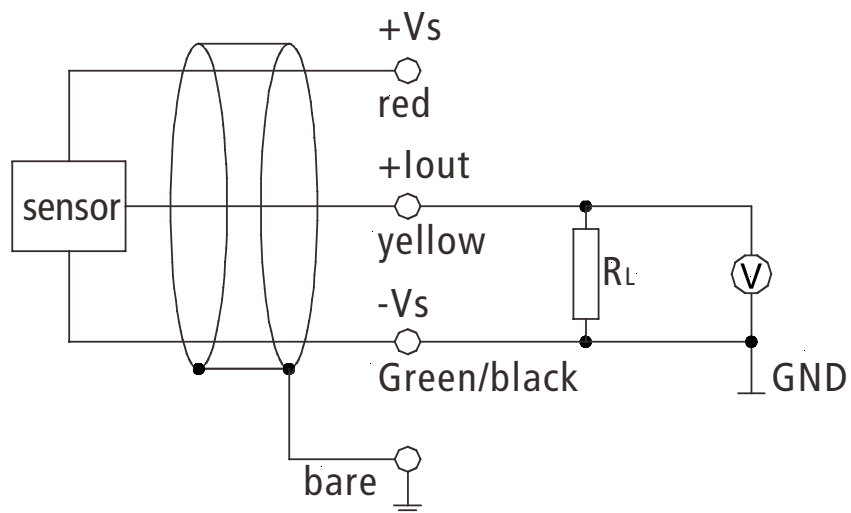

### 4...20mA output

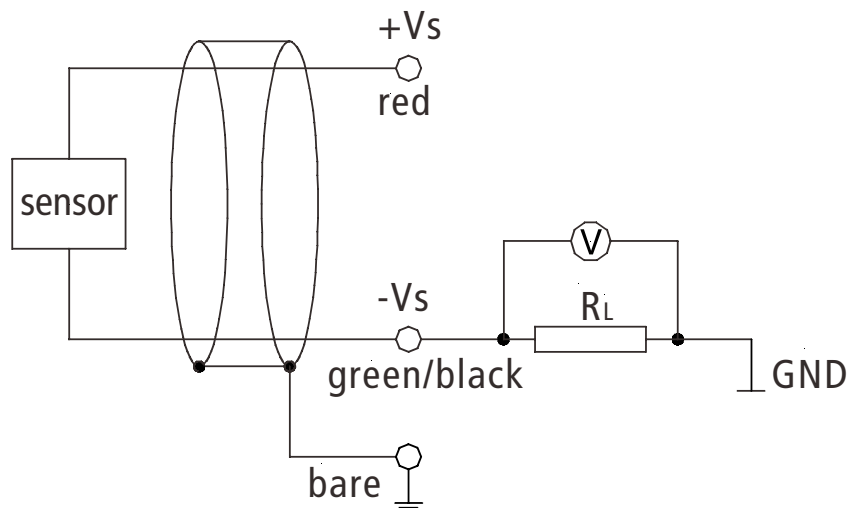

## **7. Operation, Maintenance and Failure Identification**

### **7.1 Operation**

- a. The customer could operate the transmitter without adjustment.
- b. Please be sure that the installation and electrical connection are correct or not before operation.
- c. Connect the excitation and operate.
- d. The transmitter connected with excitation could work at once, but the output signal could be more reliable after 30 minutes.

### **7.2 Maintenance**

RIL160 level transmitter needs not to be maintained regularly, but please pay attention to items as follow for better operating effect and reliability.

- a. Check wire connection is reliable or not, and the cable is aged or not.
- b. Clean the protection cap and diaphragm space regularly(take care!)
- c. Ban to pulling cables violently or poking the diaphragm with metal still objects.

### **7.2 Failure Identification**

RIL160 level transmitter is integrated full-sealed construction without movable parts inside, owning long-term stability and reliability.

If some emergencies occur, such as no output, output too little, output too large or output unreliable, please turn off the excitation firstly, then check the installation and wire connection conform the operation menu or not, the excitation is correct or not and the reference tube is unobstructed or not.

If unsuccessful, the transmitter may be destroyed, please contact with our company.



# Riels Instruments srl

Viale Spagna, 16

35020 - Ponte San Nicolò (PD) - ITALY

Ph. +39 0498961771

info@riels.it | www.riels.it