

## LEVEL INDICATOR

# MN03

Product Line: **Pressure**

Membrane indicator for signaling the level reached by the materials thanks to the pressure exerted on the instrument. Die-cast aluminum housing.



## ADVANTAGES

- An **EASY TO INSTALL** instrument that does not require any calibration, maintenance or specific tool for its installation.
- **DURABLE** and **RELIABLE** with aluminium casing, protection **IP65**.  
Relay contact rating: 10 A. at 250 V. a.c. Wiring with anti-vibration faston cable lugs. Ambient temperature for rubber membrane (MN-03) from -20 to +60°C and for viton membrane (MN-03 / V) from -20 to +80°C.



**ATEX  
DUST ZONE 22**

Product Line: Pressure

### Customizations

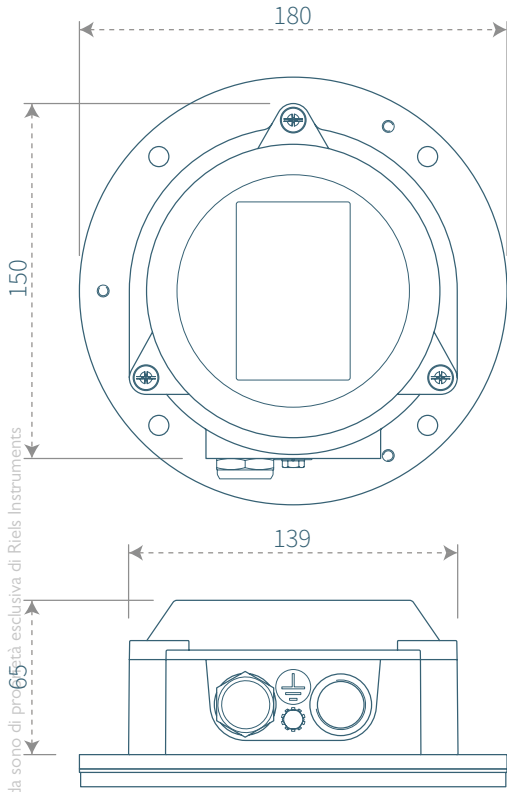

Lamp

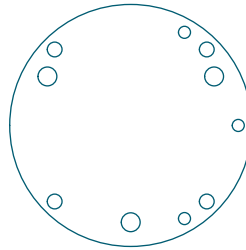

**Rubber** membrane up to **+60°C**

**FKM Viton** membrane up to **+80°C**

Tutti i dati ed i contenuti di questa scheda sono di proprietà esclusiva di Riels Instruments