



THRU-WALL LEVEL SWITCH FLD-32 "FLEXI WATCH"

CONTENTS

1. Basic description	4
2. Technical specifications	4
3. Dimensional drawings	4
4. Recommended range of application	5
5. Unsuitable range of application	5
6. Installation and setup of the sensor	5
7. Electrical connection	6
8. Sensor setup	7
9. Fault indication	8
10. Connecting the FLD-32 to the analytical units	9
11. Order code	13
12. Correct specification examples	13
13. Accessories	13
14. Protection, safety, compatibility	13

USED SYMBOLS

To ensure maximum safety of control processes, we have defined the following safety instructions and information. Each instruction is labelled with the appropriate pictogram.



Alert, warning, danger

This symbol informs you about particularly important instructions for installation and operation of equipment or dangerous situations that may occur during the installation and operation. Not observing these instructions may cause disturbance, damage or destruction of equipment or may cause injury.



Information

This symbol indicates particularly important characteristics of the device.



Note

This symbol indicates helpful additional information.

1. BASIC DESCRIPTION

Thru-wall level switch FLD-32 "Flexi Watch" is designed for indication of the presence of (conductive or non-conductive) liquids through the wall of glass or plastic vessels. The sensitivity and switching mode can be simply set up using "programming" wire or magnetic pen, depending on the type of sensor used. The sensor housing is made of a flexible polyurethane material with a self-adhesive layer and holes for fastening bands.

2. TECHNICAL SPECIFICATIONS

TECHNICAL SPECIFICATIONS		
Supply voltage		6 ... 30 V DC
Current consumption (idle-circuit condition)		max. 0.6 mA
Switched current (min. / max.)		3.3 / 40 mA
Residual voltage in the closed state		max. 6 V
Max. switching frequency		1 Hz
Ambient temperature range		-20 ... +70 °C
Diameter of the vessel for the attachment of the sensor		min. 300 mm
maximum thickness of the vessel wall	conductive liquids	8 mm
	non-conductive liquids with $\epsilon_r < 10^*$	3 mm
Protection class		IP 67
Housing material		polyurethane
Type of connection cable		PUR 3 x 0.14 mm ²
Weight (including 2 m cable)		about 40 g
Weight (without cable)		10 g

3. DIMENSIONAL DRAWINGS

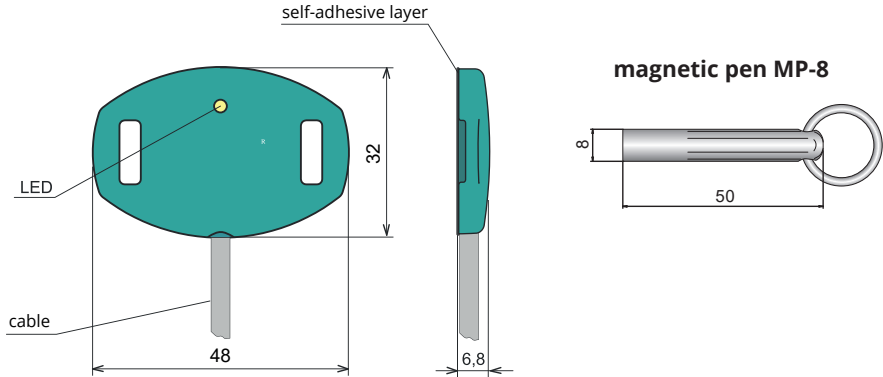

4. RECOMMENDED RANGE OF APPLICATION

Detection of various types of liquids - water, diesel fuel, oil, cooling fluids, water solutions, certain types of solvents. Suitable for plastic container tanks, plastic tubs, pools, canisters, etc.

5. UNSUITABLE RANGE OF APPLICATION

The sensor is not intended for measurement of levels on level gauges and on the walls of vessels with antistatic coating (partially conductive).

6. INSTALLATION AND SETUP OF THE SENSOR

The sensor can be attached using self-adhesive layer or using special fastening bands. Individual sensors may be arranged next to each other without any effect on their function.

FASTENING USING SELF-ADHESIVE LAYER

This technique may be used for flat or slightly curved surfaces with a diameter larger than 300 mm.

1. One protective film is removed from the adhesive layer and attached to the bottom of the sensor.
2. The target area should be cleaned and degreased.
3. Remove the second protective film and apply slight pressure to the sensor to attach it to the desired location.

When replacing or removing the sensor, the sensor should be detached from the wall of the tank carefully. If the original self-adhesive layer is destroyed, it needs to be removed from the sensor and a new one should be used (delivered as accessories).

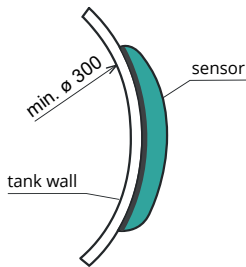

Fastening the FLD-32 using self-adhesive layer

FASTENING USING ATTACHMENT BANDS

This technique is recommended for curved surfaces with a diameter of 180 - 300 mm. Use two bands for fastening (each has one end modified).

1. The modified end of the band is threaded from the inside through the fastening eyelet and glued over.
2. The same technique is used to attach the band at the second fastening eyelet.
3. The sensor is placed at the desired location on the tank, wrapping the bands around the tank, tightening them and gluing over.

The sensor must be fastened well otherwise the function of the sensor may be unstable.

fastening bands
with \varnothing 180 - 300 mm

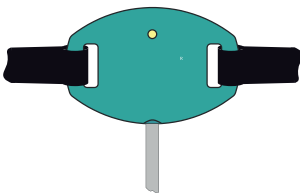

Fastening FLD-32 using attachment bands

 Attachment bands are recommended for applications where frequent removal of the sensor from the vessel surface is expected.

7. ELECTRICAL CONNECTION

The positive pole of the power supply (+U) is connected to the brown wire, the negative (0V) to the white wire. The output from the sensor is fitted with short-circuit protection. Capacitive loads and those with low resting resistance (light bulb) are evaluated by the sensor as a short-circuit.

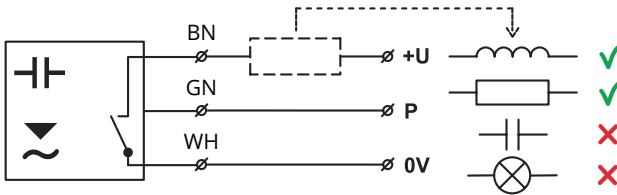

connecting the sensor with programming wire (version W)

Note: In case of strong environmental electromagnetic interference, routing of wires next to high-voltage lines or when the total distance is more than 30 m, the use of a shielded cable is recommended.

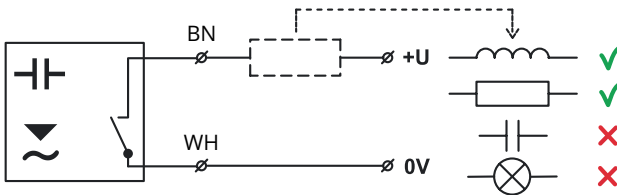

connecting the sensor without programming wire (version M)

Cable core identification:

- BN - brown
- GN - green
- WH - white

8. SENSOR SETUP

The setup is made by using green wire (**so-called programming**) at **version FLD-32N-W-S** or by touching the **magnetic pen MP-8** at **version FLD-32N-M-S** to the sensitive spot on the body of the sensor. This can be used to setup the upper and lower limits of liquid level, SO modes (open contact when the level decreases) and SC (closed contact when the level decreases).

Setup using programming wire at version FLD-32N-W-S

SO mode: open when level decreases - For empty or partially filled vessel (level under the lower edge of the sensor), the programming wire (P) is placed for about 2 seconds on terminal 0V. Once the level reaches the upper edge of the sensor or when the tank is full, the wire (P) is placed to +U terminal for the same time period (2 s).



SC mode: closed when level decreases - For empty or partially filled vessel (level under the lower edge of the sensor), the programming wire (P) is placed for about 2 seconds on terminal +U. Once the level reaches the upper edge of the sensor or when the tank is full, the wire (P) is placed to 0V terminal for the same time period (2 s).







Note: The wire (P) is used only for programming the sensor. In all other situations it is unconnected.

For comfortable setup of the FLD-32N-W-S sensor we recommend using of wall-mounted evaluation unit Riels, type SDSU-1222-W with setup buttons, power supply, optical status indication and relay output.

Set up using magnetic pen MP-8 at version FLD-32N-M-S

The setup is made by using the magnetic pen MP-8 touching on a sensitive spot  on the front side of the sensor. Short touch (for 2 s max.) of the magnetic pen on the spot  is used to open the sensor, longer touch of the magnetic pen (for 4 s min.) closes the sensor. This is used to set up the sensitivity to the measured medium and switching modes (SO, SC).

SO mode: open when the level decreases - For empty or partially filled vessel (level below the lower edge of the sensor), touch the magnetic pen on the sensitive spot for 2 s max.  (sensor opens). Once the tank is filled above the upper edge of the sensor, touch the magnetic pen on the sensitive spot for 4 s at least  (sensor closes).

SC mode: closed when the level decreases - For empty or partially filled vessel (level below the lower edge of the sensor, touch the magnetic pen on the sensitive spot for 4 s at least  (sensor closes). Once the tank is filled above the upper edge of the sensor, touch the magnetic pen on the sensitive spot for 2 s max.  (sensor opens).

9. FAULT INDICATION

control lamp	function
orange LED	permanent shine – the sensor is closed
	dark – the sensor is open
	fast flashing (0.2 s interval) * – setup error **
	slow flashing (0.8 s interval) – short-circuit at the output of the sensor.

* The sensor with "S" type of output, with each flash of LED, closes for approx. 3 ms. This is a sufficiently short period to avoid unwanted contact making of the connected relay. For binary inputs, we recommend setting up the filtration so that pulses shorter than 3 ms are not detected.

**Setting of the close (open) limits to the same level or erroneous resolution between the "close" and "open" levels (low medium permittivity).

10. CONNECTING TO THE ANALYTICAL UNITS FLD-32

The thru-wall level switch FLD-32 "Flexi Watch" can be connected to various analytical units. See below for connection examples of this setup. This provides general connection of the sensor to the relay coil and to logical unit. Connection to specific analytical units is also described.

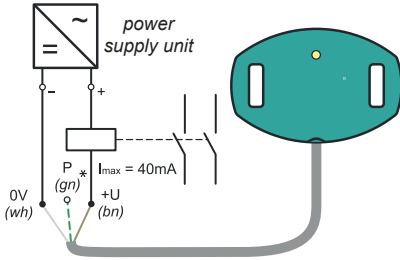

Connecting of the sensor FLD-32 to the relay coil

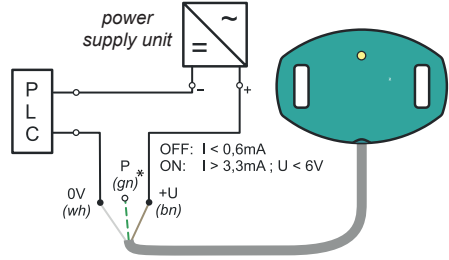

Connecting of the sensor FLD-32 to the PLC logical unit

Connecting of the sensor FLD-32 to the evaluation units SDSU-1222-W and DSU-1222-W

This unit is intended for evaluation of sensors programmable using third wire (FLD-32 "Flexi Watch"). It contains the programming buttons for setup of sensors and stabilized 12 V DC power supply. It enables the level control (sensing of the amount of liquid in tanks, wells, etc.) This unit is suitable for the FLD-32 variant with programming wire setup. DSU-1222-W unit is suitable for the type with magnetic pen setup.

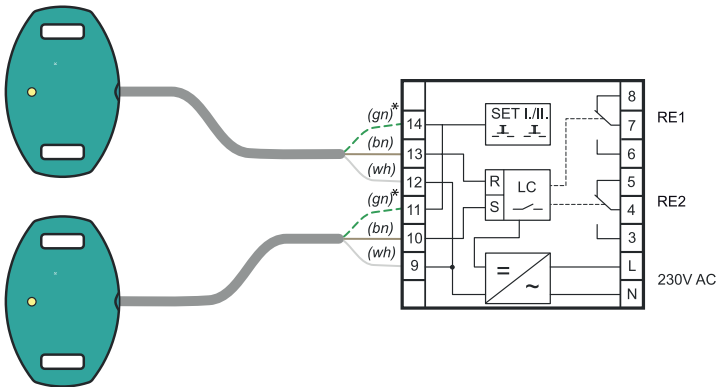

Connecting of the sensor FLD-32 to the evaluation unit SDSU-1222-W

Legend:

wh – white
bn – brown
gn – green

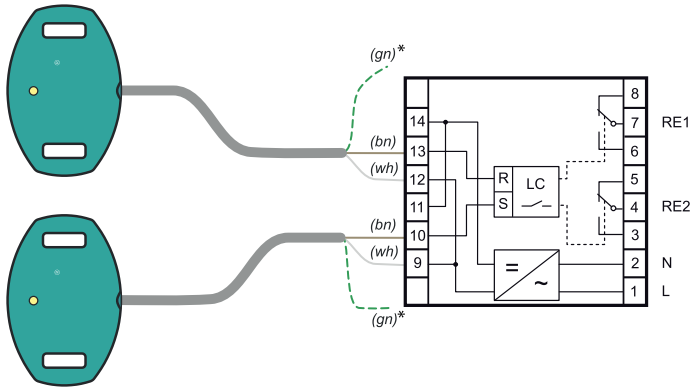

Connecting of the sensor FLD-32 to the evaluation unit DSU-1222-W

Connecting of the sensor FLD-32 to the evaluation units LCU-1232 and LCU-1221

These units have two inputs to connect two operating sensors (MIN, MAX) and one input for connection of an emergency sensor (ALARM - only LCU-1232). The operating sensors enable the control of the operating relay (terminals 14, 15, 16). The emergency sensor controls the emergency relay (terminals 11, 12).

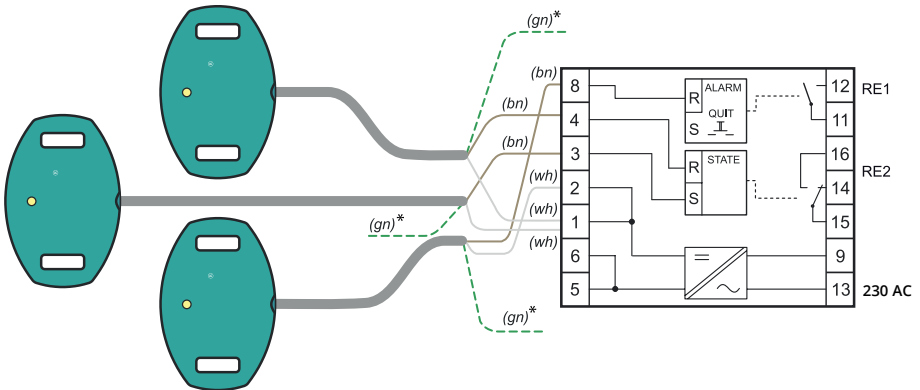

Connecting of the sensor FLD-32 to the evaluation unit LCU-1232

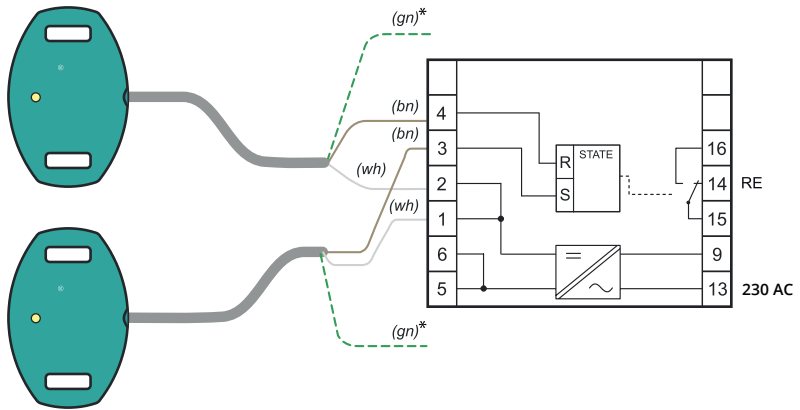

Connecting of the sensor FLD-32 to the evaluation unit LCU-1221

Connecting of the sensor FLD-32 to the evaluation units SSU-1211-W and DSU-1222-W

The unit SSU-1211 is used to connect a single sensor. It has one contact for the input signal (terminal 3) and relay contact (12, 15, 16). To use the unit in combination with FLD-32, terminal 4 must be connected to terminal 5. The unit DSU-1222 is used to connect two sensors. It has two contacts for the input signals (terminals 3 and 4) and relay contact (11, 12 and 15, 16).

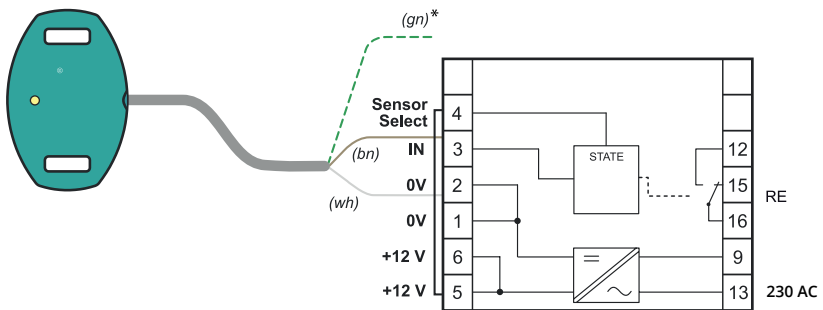

Connecting of the sensor FLD-32 to the evaluation unit SSU-1211

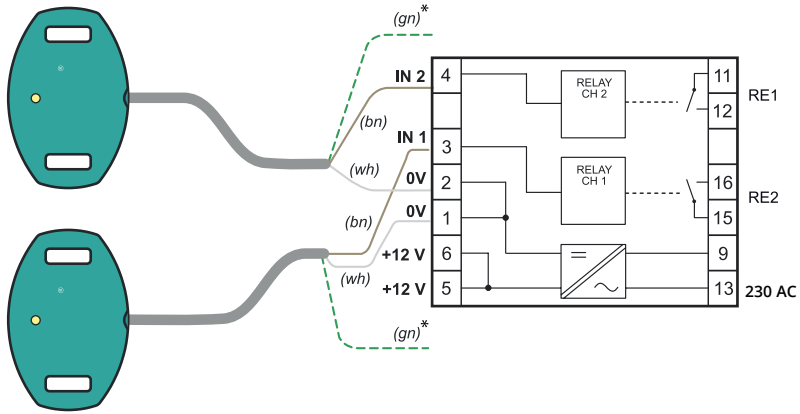

Connecting of the sensor FLD-32 to the evaluation unit DSU-1222

Connecting of the sensor FLD-32 to the evaluation units TDU-1211

This unit has one input for connection of one limit sensor. The defined change of status on unit input (terminal No.3 - IN) starts the timer in the range from 1 s to 100 min. While the timer is running, the condition of the output relay changes (relay with switching contact) and contact is made between terminals 12 and 16 (disconnected contact 15-16).

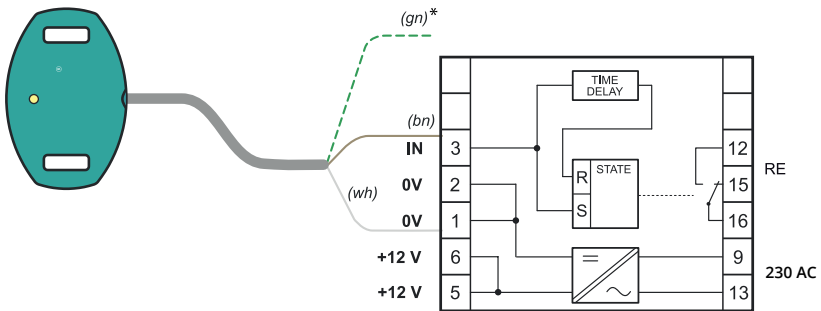
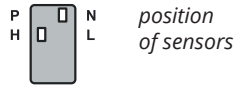

Connecting of the sensor FLD-32 to the evaluation unit TDU-1211

* Only for version FLD-32N-W-S.

11. ORDER CODE

PRODUCT	
FLD-32	
PERFORMANCE	
N	non-explosive areas
SETUP TECHNIQUE	
M	magnetic pen
W	programming wire
TYPE OF OUTPUT	
S	electronic switch
CABLE	
K	cable length in m (2 or 5 m)
FLD-32 N - W - S - K 2	AVAILABLE PRODUCT ALTERNATIVES

12. CORRECT SPECIFICATION EXAMPLES

FLD - 32N-M-S K 2

FLD - 32N-W-S K 5

13. ACCESSORIES

standard - included in the price of the sensor

- 2x two-sided adhesive layer
- 1x magnetic pen MP-8 (in case of version that uses MP-8 setup)

optional - for an extra charge

- attachment band (1 packaging - 2x 0.5 m)
- two-sided adhesive layer

14. PROTECTION, SAFETY, COMPATIBILITY

The sensor is fitted with the protection of supply voltage against polarity reversal, voltage peaks and current overload.

Shock protection is provided by safe supply voltage according to HD 60364-4-41. Electromagnetic compatibility is provided by compliance with standards EN 55022/B, EN 61326-1, EN 61000-4-2, -4-3, -4-4 and -4-6.

