

Product introduction

Description

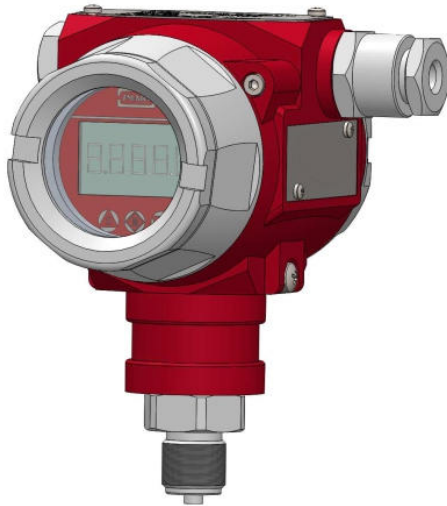

Monosilicon pressure transmitter

RIB305X monosilicon pressure transmitter is a high performance pressure transmitter with international leading technology meticulously designed by RIELS instrument, using the world's most advanced monosilicon pressure sensor technology and patent encapsulation technology. Monosilicon pressure sensor locates on the top of the metal body and stay away from the medium interface to realize mechanical isolation and thermal isolation. Glass sintering sensor wire realizes high strength electrical insulation of metal base and improves the capability of flexibility of electronic circuit and transient voltage resistance protection. All these original encapsulation technologies enable RIB305X to easily cope with extreme chemical occasion and mechanical load, and own strong resistance to EMI, sufficient to respond to the most rigorous industrial environment applications, which are the genuine invisible instruments.

Main parameters

Pressure types	Absolute pressure
Measuring range	40kPa-10MPa, please refer to the ordering information chapter
Output signal	4-20mA, 4-20mA+HART, customer
Reference accuracy	±0.15% URL, optional ±0.1% URL

Field of application

Pressure

Approvals



Measuring medium

The fluids which compatible with wetted parts

Technical Specifications

Measuring range and limit

Nominal value	Smallest calibratable span	Lower range limit(LRL)	Upper range limit(URL)	Overload limit
40kPa	2kPa	0kPa	40kPa	1MPa
250kPa	12.5kPa	0kPa	250kPa	4MPa
1MPa	50kPa	0kPa	1MPa	6MPa
10MPa	500kPa	0kPa	10MPa	20MPa

Above measurement range can be replaced by kg/cm², MPa and kPa units .Which can provide other measurement range according to the requirements. Adjust requirements: lower range value (LRV) and upper range value (URV) can be adjusted within the scope of the upper and lower range limit, smallest calibratable span ≤ | URV-LRV | ≤ upper range limit

Standard specifications and reference conditions

Test standard: GB/T28474 / IEC60770; Zero based-calibration span, Silicon oil filling, 316L stainless steel isolated diaphragm, 4-20mA analog output.

Performance specifications

The overall performance including but not limited to 【 reference accuracy 】 , 【 environment temperature effects 】 and other comprehensive error

Typical accuracy: ±0.15%URL

Stability: ±0.2% URL/ 5 years

Reference accuracy

Standard and reference conditions, including linearity (BFSL), hysteresis and repeatability. calibration temperature: 20 °C ± 5 °C

Linear output accuracy	TD≤10(Note1)	±0.15%URL	Nominal value: 40kPa, 250kPa 1MPa, 10MPa
	10<TD<20	±0.015TD% URL	

Note 1: TD is Turn down, TD=URL/ |URV-LRV|

Power supply effects

Zero and span change should not be more than ± 0.005% URL/V when power supply changes in 10.5/16.5-55VDC

Mounting position effects

Apply to any position. Max value lower than 400Pa can be corrected by zero clearing function.

Vibration effects

According to GB/T 1827.3/IEC61298-3 tests, <0.1% URL

Output signal

4-20mA two wire. Customers can choose linear output or square root output. Digital process variables superimpose on 4-20mA signal and apply to any hosts with HART protocol.

Ambient temperature effects(Typical)

Within the range -20-80 °C total impact ±(0.1+0.15TD)% URL

Insulation resistance

≥ 20M Ω@, 100VDC

Disclaimer: all the data used in the product description is not legally binding. Relevant technical details may be changed due to further improve

Technical Specifications

Damping time

Total damping time constant: equal to the sum of damping time of amplifier and sensor capsule
Damping time of amplifier: 0-100S adjustable
Diaphragm capsule (isolated diaphragm and silicon oil filling) damping time: $\leq 0.2s$
Startup after power off: $\leq 6S$
Normal services after data recovery: $\leq 31S$

Weight

Net weight: about 1.87kg (without mounting bracket and process connection adaptor)

Environment condition

Items	Operational condition
Working temperature	-40-85°C, integrated LCD display: -20-70°C
Storage temperature	-40-110°C, integrated LCD display: -40-85°C
Media temperature	Silicon oil filling: -40-120°C
Working humidity	5-100% RH@40°C
Protection class	IP67

EMC environment

NO.	Test items	Basic standards	Test conditions	Performance level
1	Radiated interference	GB/T 9254/CISPR22	30MHz-1000MHz	OK
2	Conducted interference (DC power port)	GB/T 9254/CISPR22	0.15MHz-30MHz	OK
3	Electrostatic discharge immunity test (ESD)	GB/T 17626.2/IEC61000-4-2	4kV(Contact), 8kV(Air)	B(Note2)
4	Immunity to radio frequency EM-fields	GB/T 17626.3/IEC61000-4-3	10V/m(80MHz-1GHz)	A(Note1)
5	Power frequency magnetic field Immunity test	GB/T 17626.8/IEC61000-4-8	30A/m	A(Note1)
6	Electrical fast transient / Burst Immunity Test	GB/T 17626.4/IEC61000-4-4	2kV(5/50ns, 100kHz)	B(Note2)
7	Surge immunity requirements	GB/T 17626.5/IEC61000-4-5	1kV(Line to line) 2kV(Line to ground) (1.2us/50us)	B(Note2)
8	Immunity to conducted disturbances induced by radio frequency fields	GB/T 17626.6/IEC61000-4-6	3V(150kHz-80MHz)	A(Note1)

(Note 1) Performance level A: The performance within the limits of normal technical specifications.

(Note 2) Performance level B: Temporary reduction or loss of functionality or performance, it can restore itself. The actual operating conditions, storage and data will not be changed.

Disclaimer: all the data used in the product description is not legally binding. Relevant technical details may be changed due to further improve

Power supply

Item	Operating conditions
Standard/flame proof	10.5-55VDC
HART protocol	16.5-55VDC, communication load resistance 250Ω
Load resistance	0-2119 Ω for working condition, 250-600Ω for HART protocol
Transmission distance	<1000m
Power consumption	$\leq 500mW@24VDC$, 20.8mA

Power supply and load requirements

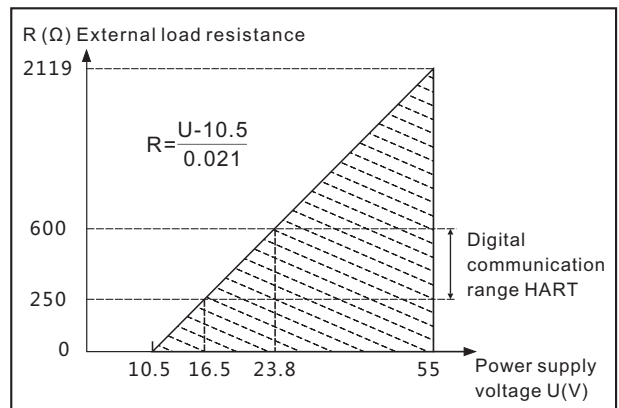

Menu function

Specific menu

Transmission module type

Output signal	Local control	Remote control
4-20mA+HART	LCD/3 buttons on body	HART
4-20mA	LCD/3 buttons on body	-

LCD display unit

Display mode	Details
PV	Process variable shows on main screen, percentage and progress bar shows on secondary screen
mA	Current shows on main screen, percentage and progress bar shows on secondary screen
%	Percentage shows on main screen, percentage and progress bar shows on secondary screen

Unit

Unit	Definition
kPa	Kilopascal
MPa	Megapascals
bar	Bar
psi	Pounds per square inch
mmHg	Millimetre(s) of mercury@0°C
mmH2O	Millimeter of water@4°C
mH2O	Meter of water@4°C
inH2O	Inches of water@4°C
ftH2O	Feet of water@4°C
inHg	Inches of mercury@0°C
mHg	Meter mercury column@0°C
TORR	Torr
mbar	Millibar
g/cm2	Gram per square centimeter
kg/cm2	Kilogram per square centimeter
Pa	PA
ATM	Standard atmospheric pressure
mm	Millimeter(Note 1)
m	Meter(Note 1)

Note1: length unit need mark medium density

Measuring menu set

Mark	State
URV	Upper range value, 20mA
LRV	Lower range value, 4mA

Damping time

Units	Setting range
S	0-100

Analog output type

Parameters	Output type
mA LINER	Linearity
mA $\sqrt{\quad}$	Square root

Alarm signal

Parameters	Alarm signal
ALARM NO	None
ALARM H	20.8mA
ALARM L	3.8mA

Fix output

Parameters	Fix output value
FIX/C NO	None
3.8000	3.8000mA
4.0000	4.0000mA
8.0000	8.0000mA
12.000	12.000mA
16.000	16.000mA
20.000	20.000mA
20.800	20.800mA

Quick menu

Parameter	Instruction
PV=0	Set current output to zero value, used to correct the error caused by static pressure and installation.
Zero adjustment	4mA re-range with pressure
Span adjustment	20mA re-range with pressure
Restore factory setting	Restore backup data when error

Disclaimer: all the data used in the product description is not legally binding. Relevant technical details may be changed due to further improve

Product selection instruction

Sensor select instruction

Code	Nominal value	Description
S403A	40kPa	Range 0-40kPa, smallest calibratable span 2kPa
S254A	250kPa	Range 0-250kPa, smallest calibratable span 12.5kPa
S105A	1MPa	Range 0-1MPa, smallest calibratable span 50kPa
S106A	10MPa	Range 0-10MPa, smallest calibratable span 500kPa

Adjust requirements: lower range value (LRV) and upper range value (URV) can be adjusted within the scope of the upper and lower range limit, minimum measuring range $\leq |URV - LRV| \leq$ maximum measuring range

Code	Position	Description
S	Diaphragm material	SUS316L
H		Hastelloy C
S	Isolated filling fluid	Silicon oil, process temperature: -45-205°C
D		Fluorocarbon oil, process temperature: -10-160°C
F	Sensor seal	Stainless steel welding seal

Diaphragm(S/H)



Electrical connection

Code	Item	Description
T1	Electrical connection	Aluminum-alloy terminal, 2 cable entry M20*1.5(F), red body, white cover
R1	Cable entry protector	Waterproof connector M20*1.5 one side, blind plug another side, PVC material, 6-8mm diameter cable only, IP67
R2		Flame proof, 1/2 NPT(F) one side, blind plug another side, stainless steel material, 6-8mm diameter cable only, IP67
R3		Flame proof, M20X1.5(F) one side, blind plug another side, stainless steel material, 6-8mm diameter cable only, IP67

Housing(T1)

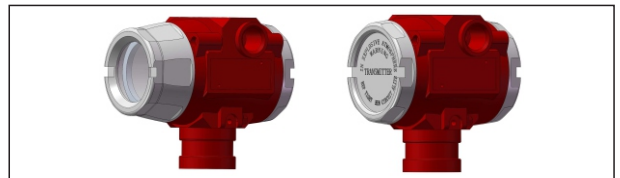

Standard cable entry protective adaptor(R1)

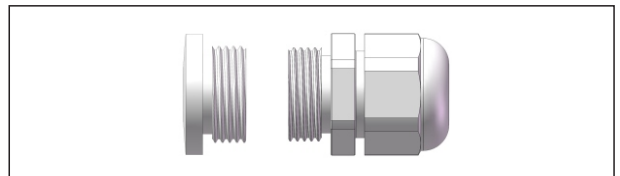

Flame proof cable entry protective adaptor(R2/R3)

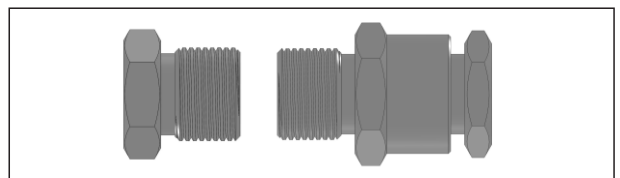

Disclaimer: all the data used in the product description is not legally binding. Relevant technical details may be changed due to further improve

Product selection instruction

Transmission module

Code	Items	Description
F	Output signal	4-20mA two wire, power supply: 10.5-55VDC
H		4-20mA+HART two wire, power supply: 16.5-55VDC
A	Display	Without display
C		With LCD display

Display module(C)



Terminals

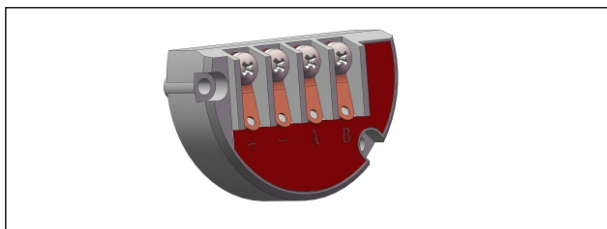

Process connection select instruction

Code	Items	Description
6	Material	Stainless steel, SUS316
M01	Specifications	M20*1.5(M), Φ3 pressure lead hole, GB/T193-2003, ISO261
G01		G1/2(M), Φ3 pressure lead hole, EN837
G02		G1/4(M), Φ3 pressure lead hole, EN837

G08		G1/4(M), Φ3 pressure lead hole, GB/T7307, ISO228, DIN16288, BS2779, seal reference DIN3852-E(back-end seal)
R01		1/2-14NPT(M), Φ3 pressure lead hole, GB/T12716, ANSI/ASME B1.20.1
R02		1/4-18NPT(M), Φ3 pressure lead hole, GB/T12716, ANSI/ASME B1.20.1
R03		1/2-14NPT(F), GB/T12716, ANSI/ASME B1.20.1
R04		1/4-18NPT(F), GB/T12716, ANSI/ASME B1.20.1

Brackets

Code	Items	Instruction
B4	Fixed mounting	U-shaped bracket, 2" pipe, apply to T-structure

Fixed mounting bracket (B4) (RIB305X-TST-S)

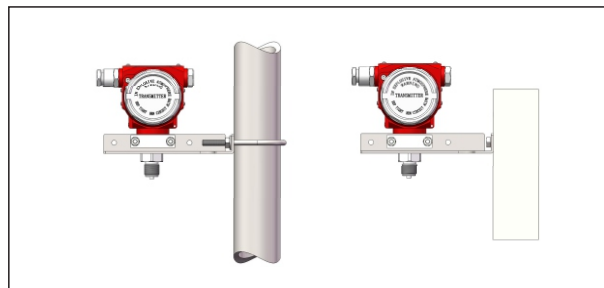

Disclaimer: all the data used in the product description is not legally binding. Relevant technical details may be changed due to further improve

Product drawing and dimension

Drawing and dimension of RIB305X-TST-S with display(C) (unit: mm)

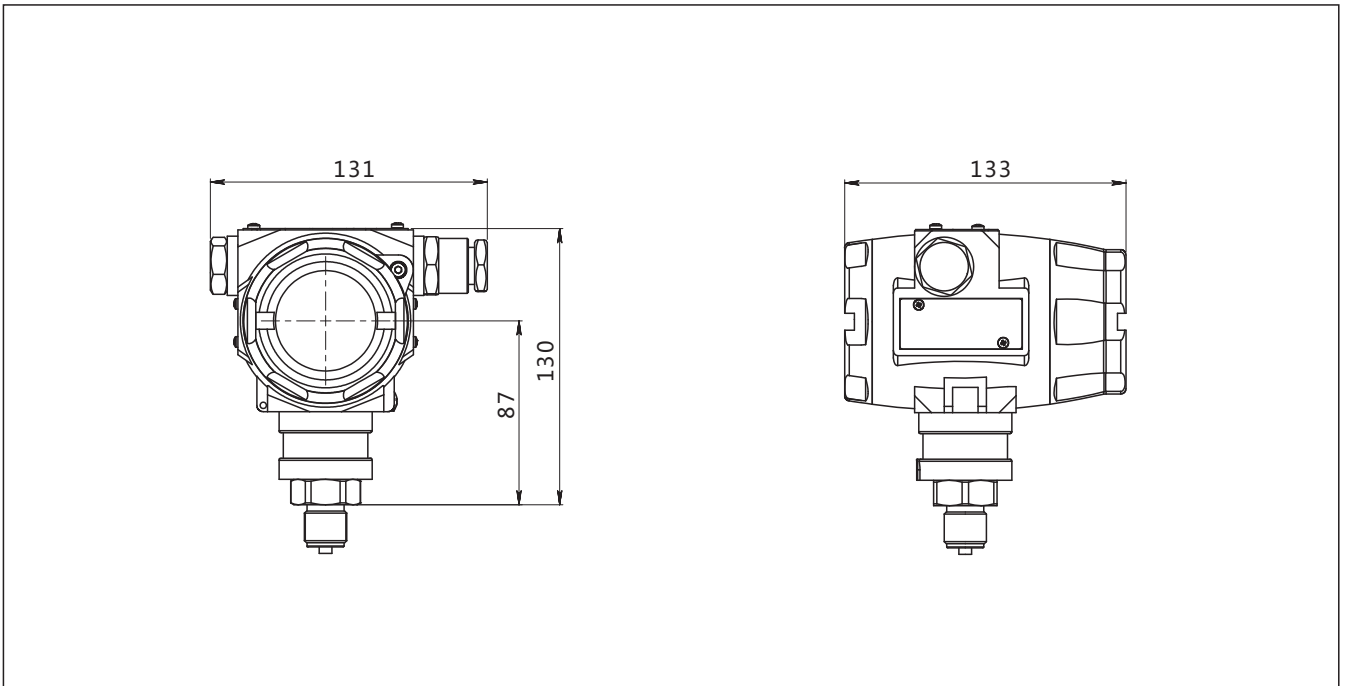

Drawing and dimension of RIB305X-TST-S without display(A) (unit: mm)

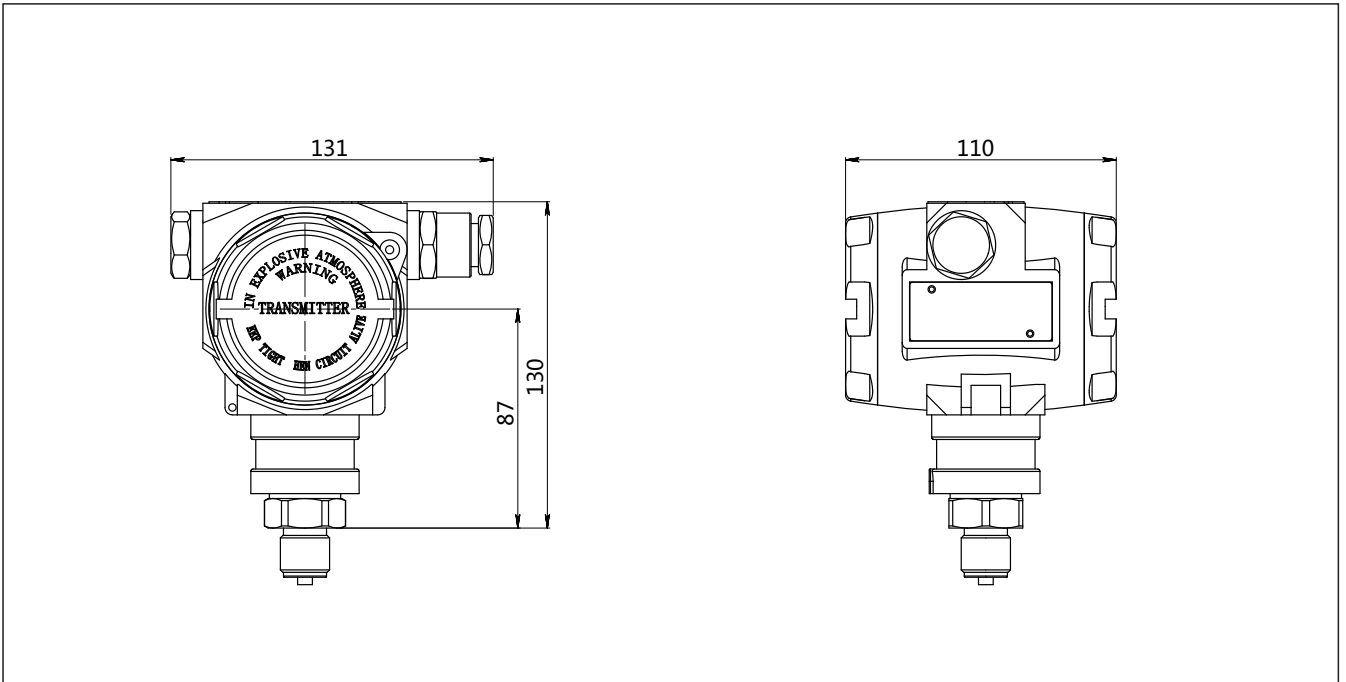

Disclaimer: all the data used in the product description is not legally binding. Relevant technical details may be changed due to further improve

Product drawing and dimension

Fixed mounting bracket installation dimension of RIB305X-TST-S (B4) (unit: mm)

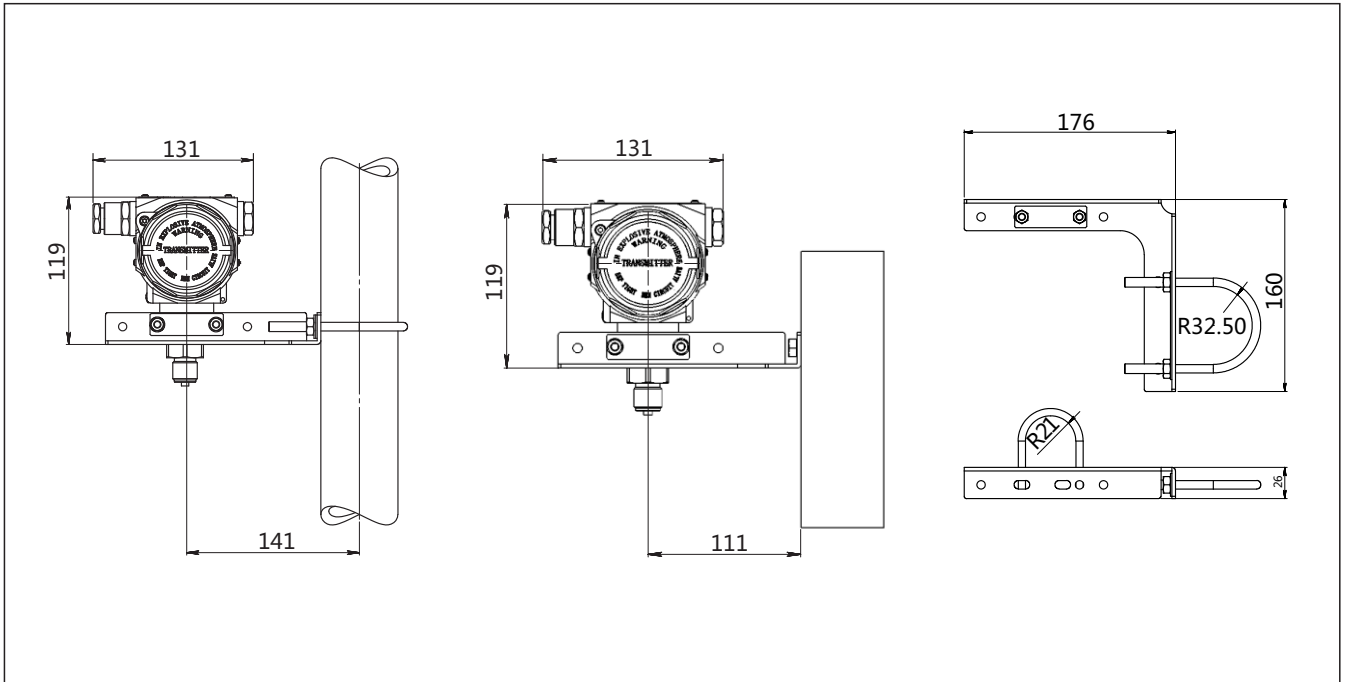

Process connection(M01) (unit: mm)

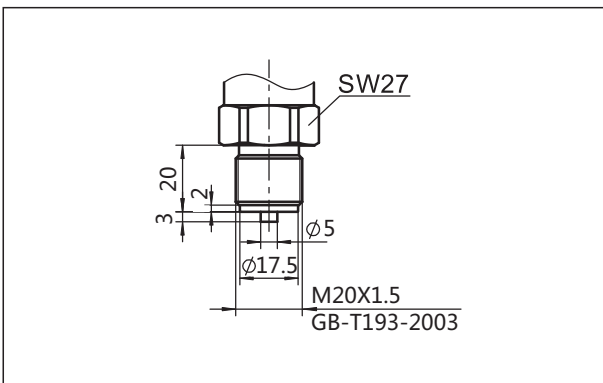

Process connection(G01) (unit: mm)

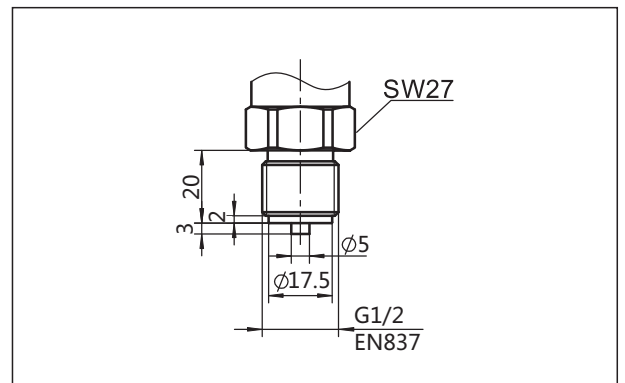

Disclaimer: all the data used in the product description is not legally binding. Relevant technical details may be changed due to further improve

Product drawing and dimension

Process connection(G02) (unit: mm)

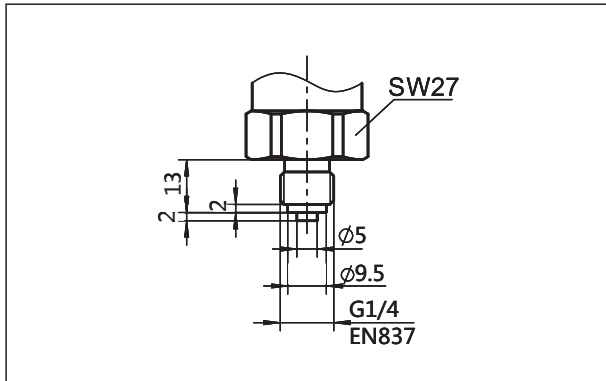

Process connection(G08) (unit: mm)

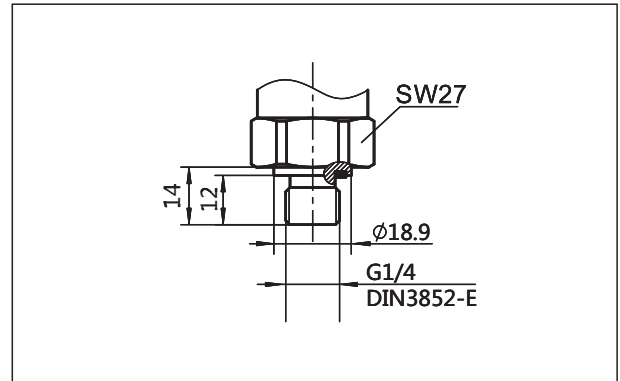

Process connection(R01) (unit: mm)

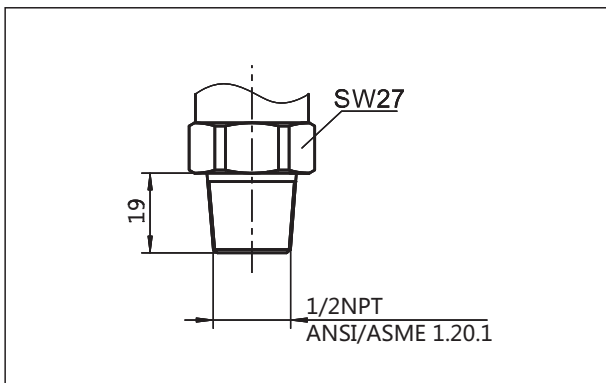

Process connection(R02) (unit: mm)

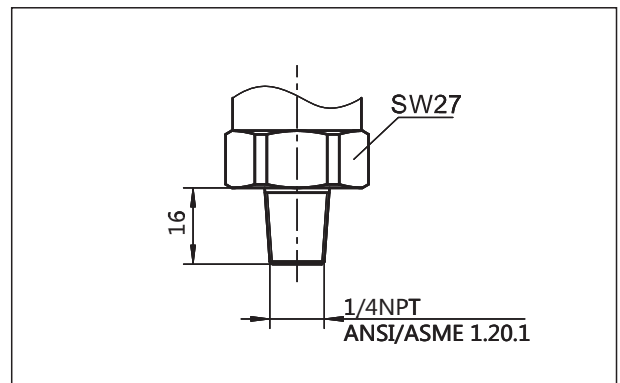

Process connection(R03) (unit: mm)

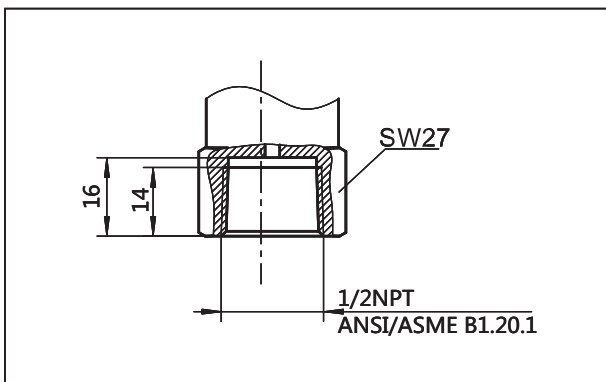

Process connection(R04) (unit: mm)

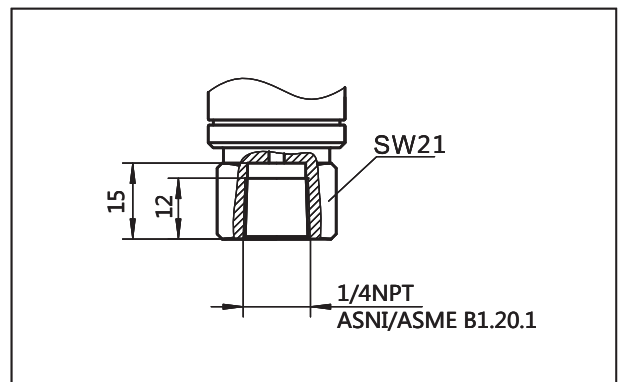

Disclaimer: all the data used in the product description is not legally binding. Relevant technical details may be changed due to further improve

Product drawing and dimension

Heat exchange connector(N1) (unit: mm)

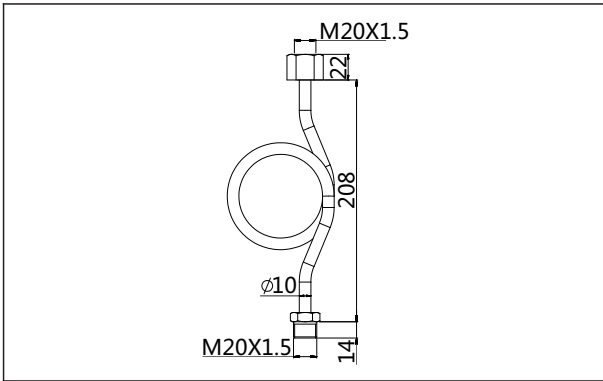

Heat exchange connector(N2)(unit: mm)

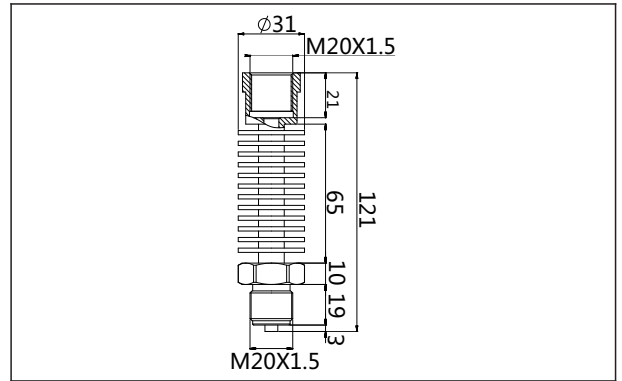

Welding adaptor(Z1) (unit: mm)

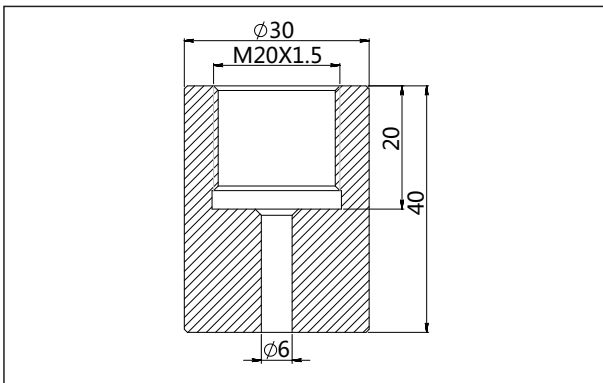

Welding adaptor(Z2) (unit: mm)

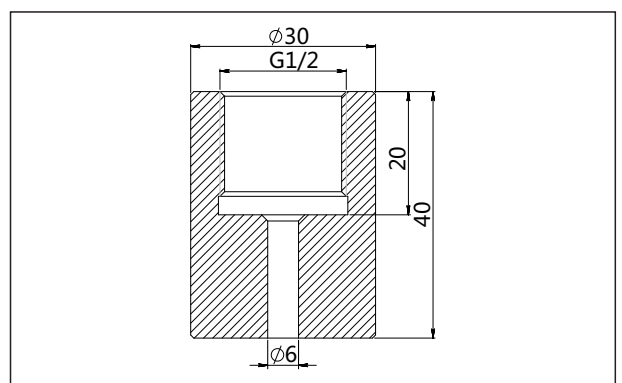

Ordering information chapter

Item	Parameters	Code	Instruction	(*) fast delivery available	
	Model	RIB305X-TST	Monosilicon absolute pressure transmitter		
Sensor	Separator	-	Detailed specifications as following		
	Pressure range code	S403A	Nominal value(URL): 40kPa		
		S254A	Nominal value(URL): 250kPa	*	
		S105A	Nominal value(URL): 1MPa	*	
		S106A	Nominal value(URL): 10MPa	*	
	Diaphragm material	S	SUS316L		*
		H	Hastelloy C		
	Isolated filling fluid	S	Silicon oil, process temperature: -45-205°C		
D		Fluorocarbon oil, process temperature: -10-160°C			
Sensor seal	F	Stainless steel welding seal			
Electrical connection	Separator	-	Detailed specifications as following		
	Electrical connection	T1	Aluminum-alloy terminal, 2 cable entry M20*1.5(F), red body, white cover	*	
	Cable entry protector	R1	Waterproof connector M20*1.5 one side , blind plug another side, PVC material, 6-8mm diameter cable only, IP67	*	
		R2	Flame proof, 1/2 NPT(F) one side, blind plug another side, stainless steel material, 6-8mm diameter cable only, IP67		
		R3	Flame proof, M20*1.5(F) one side, blind plug another side, stainless steel material, 6-8mm diameter cable only, IP67		
Output	Separator	-	Detailed specifications as following		
	Output signal	F	4-20mA two wire, power supply: 10.5-55VDC		
		H	4-20mA+HART two wire, power supply: 16.5-55VDC	*	
	Display	C	LCD display	*	
		A	Without LCD display		
Process connection	Separator	-	Detailed specifications as following		
	Material	6	SUS316	*	
	Specification	M01	M20*1.5 (M), Φ 3 pressure lead hole, GB/T193-2003, ISO261	*	
		G01	G1/2 (M), Φ 3 pressure lead hole, GB/T7307, ISO228, DIN16288, BS2779	*	
		G02	G1/4(M), Φ 3 pressure lead hole, EN837		
		G08	G1/4(M), Φ 3 pressure lead hole, GB/T7307, ISO228, DIN16288, BS2779, seal refers to DIN3852-E (back-end seal)		
		R01	1/2 -14NPT(M), Φ 3 pressure lead hole, GB/T12716, ANSI/ASME B1.20.1	*	

Disclaimer: all the data used in the product description is not legally binding. Relevant technical details may be changed due to further improve

Ordering information chapter

		R02	1/4 -18NPT(M), Φ 3 pressure lead hole, GB/T12716, ANSI/ASAME B1.20.1	
		R03	1/2 -14NPT(F), GB/T12716, ANSI/ASME B1.20.1	
		R04	1/4 -18NPT(F), GB/T12716, ANSI/ASME B1.20.1	
Additional options	Separator	-	Detailed specifications as following	
	Fixed mounting accessory	/B4	U-shaped bracket, 2" pipe, apply to T-structure	*
	Process connection mounting accessory	/N1	Heat exchange connector, M20*1.5 (F) change to M20*1.5(M), SUS304 (Condenser pipe)	*
		/N2	Heat exchange connector, M20*1.5 (F) change to M20*1.5(M), SUS304 (Cooling fin)	*
	Process connection accessory	/Z1	Welding adaptor, M20*1.5(F), SUS304	*
		/Z2	Welding adaptor, G1/2(F), SUS304	*
	Display mode	/D1	According to your requirements	
	Calibration report	/Q1	Calibration report provided by our company	
	Approvals (multiple)	/E1	Flame proof certificate, ExdIICT6, NEPSI	*
		/I1	Intrinsic safety certificate, ExialICT4, NEPSI	*
		/F3	CE certificate	*

Factory settings and parameters

Item	Menu mark	Factory setting value
Tag position	None	0(No specific settings)
Analog output type	mA	Liner(No specific settings)
Display mode	DISP	PV(No specific settings)
Alarm signal	ALARM	No(No specific settings)

Item	Menu mark	Factory setting value
Damping value	DAMP	0(No specific settings)
4mA Lower range value	LRV	According to the order
20mA Upper range value	URV	According to the order
Process unit	U	According to the order

Approvals

Factory certificate

Certification organization	Intertek
Quality management system	ISO9001-2008
Scope of certification	Design and production of pressure transmitter
Registration number	110804039

Intrinsic safety certificate

Certification organization name	NEPSI
License range	RIB305X series pressure/ differential pressure transmitter
Explosion-proof mark	ExIICT4
Ambient temperature	-40-+60°C
Medium maximum temperature	+120°C
Registration number	GYB16.1962X
Intrinsically safe parameter description	Maximum input voltage: 28VDC
	Maximum input current: 100mA
	Maximum input power: 0.7w
	Maximum internal equivalent parametersCi(nF): 0
	Maximum internal equivalent parametersLi(mH): 0.01

CE

Certificate organization	ISET
License scope	RIB305X pressure/ differential pressure transmitter
Mark	CE
EMC instruction	2014/30/EU
Standard	EN61326-1: 2013
Registration number	IT041353LG161207

Flame proof certificate

Certificate organization	NEPSI
License scope	RIB305X pressure/differential pressure transmitter
Explosion-proof mark	ExdIICT6
Working environmental temperature	-25-+60°C
Maximum medium temperature	+80°C
Registration number	GYB16.1254X