



# Series 1800 Low Differential Pressure Switches for General Industrial Service

## Specifications - Installation and Operating Instructions



**Model 1823 pressure switch.**  
UL and CSA Listed, FM and  
CENELEC approved.

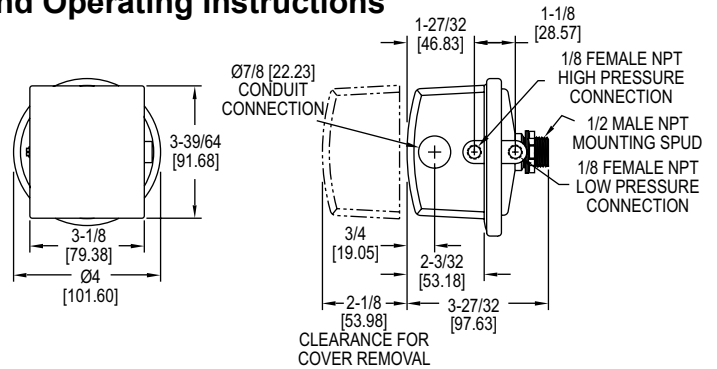

Construction and dimensions. Series 1823 pressure switches.

One of our most popular pressure switches. Combines small size and low price with 2% repeatability for enough accuracy for all but the most demanding applications. Set point adjustment inside the mounting switch on one side of a wall or panel with adjustment easily accessible on the opposite side.

\*Model 1823 shown; (1823 replaces 1820, 1821 and 1822 which are similar).

### Environmental (MIL) Switch

Unlisted Model 1820 can be furnished with special snap switch sealed against the environment for high humidity and/or for government applications. Similar to standard Model 1823 except dead band is slightly greater. Specify Model 1820 (Range No.) "MIL" in ordering.

MODEL CHART			
Model	Operating Range, in w.c.	Approximate Dead Band	
		At Min. Set Point	At Max. Set Point
1823-00	0.07 to 0.22	0.05	0.05
1823-0	0.15 to 0.5	0.06	0.06
1823-1	0.3 to 1.0	0.08	0.08
1823-2	0.5 to 2.0	0.10	0.12
1823-5	1.5 to 5.0	0.14	0.28
1823-10	2.0 to 10	0.18	0.45
1823-20	3 to 22	0.35	0.70
1823-40	5 to 44	0.56	1.10
1823-80	9 to 85	1.30	3.0

### INSTALLATION

- Select a location free from excessive vibration and where oil or water will not drip upon the switch. See special housings for unusual conditions.
- While not required, positioning the pressure connections down is recommended. Mount the switch with the diaphragm in a vertical plane. Switch with the diaphragm in a vertical plane. Switch must be recalibrated for each change in operating position.
- Connect switch to source of pressure differential. Metal tubing with 1/4" O.D. is recommended but any tubing system which will not restrict the air flow is satisfactory. Note that the low pressure connection may be made to the 1/2" spud at the back of the switch if desired. If so connected, drill 1/16" diameter holes in the Spring Retainer flange and the head of Adjustment Screw to provide opening to the switch interior and plug the other low pressure connection.
- Electrical connections to the standard single pole, double throw snap switch are provided by means of screw terminals marked "common", "norm open", and "norm closed". The normally open contacts close and the normally closed contact open when pressure increases beyond the set point.
- Switch loads should not exceed the maximum specified current rating of 15 amps resistive. Switch capabilities decrease with high load inductance or rapid cycle rates. Whenever an application involves one or more of these factors, the user may find it desirable to limit the switched current to 10 amps or less in the interest of prolonged switch life.

### ADJUSTMENT

- If the switch has been factory preset, check the set-point before placing in service to assure it has not shifted in transit.
- If switching has not been preset or it is desired to change the point, observe the following procedure:
  - To adjust the set point turn the slotted Adjustment Screw clockwise to increase the set point and counterclockwise to decrease the set point.
  - The following is a recommended procedure for calibrating or checking calibration: Use a "T" assembly with three rubber tubing leads, all as short as possible and the entire assembly offering minimum flow restriction. Run one lead to the pressure switch, another to a manometer of known accuracy and appropriate range, and apply pressure through the third tube. Make final approach to the set point slowly. Note the manometer and pressure switch will have different response characteristics due to different internal volumes, lengths of tubing, oil drainage, etc. Be certain switch is checked in position it will assume in use, i.e. vertical, horizontal, etc.

### SPECIFICATIONS

**Service:** Air and non-combustible, compatible gases.  
**Wetted Materials:** Consult factory.  
**Temperature Limits:** -30 to 180°F (-34 to 82.2°C). 1823-00, -20 to 180°F (-28.9 to 82.2°C).  
**Pressure Limits:** 10 psig (68.95 kPa) continuous, 25 psig (172.4 kPa) surge.  
**Switch Type:** Single-pole double-throw (SPDT).  
**Repeatability:** ±2%.  
**Electrical Rating:** 15 A @ 120-480 VAC, 60 Hz. Resistive 1/8 HP @ 125 VAC, 1/4 HP @ 250 VAC, 60 Hz. De-rate to 10 A for operation at high cycle rates.

**Electrical Connections:** 3 screw type, common, normally open and normally closed.  
**Process Connections:** 1/8" female NPT.  
**Mounting Orientation:** Diaphragm in vertical position. Consult factory for other position orientations.  
**Set Point Adjustment:** Screw type inside mounting spud.  
**Weight:** 1 lb, 5 oz (595 g).  
**Agency Approvals:** CE, UL, CSA, FM.



### Weatherproof Enclosure

16 ga. steel enclosure for unusually wet or oily conditions. Withstands 200 hour salt spray test. Gasketed cover. Weight 5-1/2 lb (2.5 kg). Switch must be installed at factory. Specify "WP" in addition to switch catalog number.

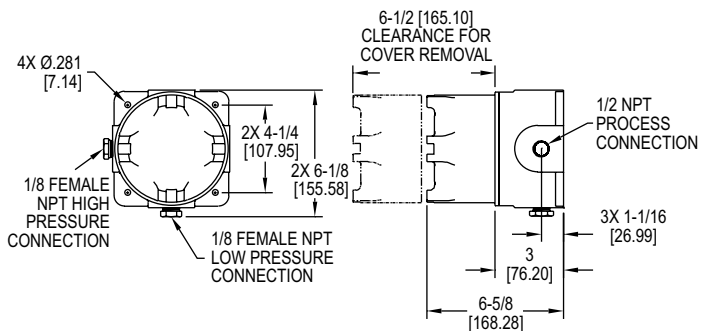

### Explosion-Proof Housing

Cast iron base and aluminum dome cover. Approximate weight 7-1/2 lb (3.4 kg). Specify "EXPL" in addition to switch catalog number. Rated Class I, Groups C & D, Div. 1. Class II, Groups E, F, & G, Div. 1.

# Serie 1800 Interruptor Para Baja

## Presión Diferencial



Model 1823 pressure switch. UL and CSA Listed, FM approved.

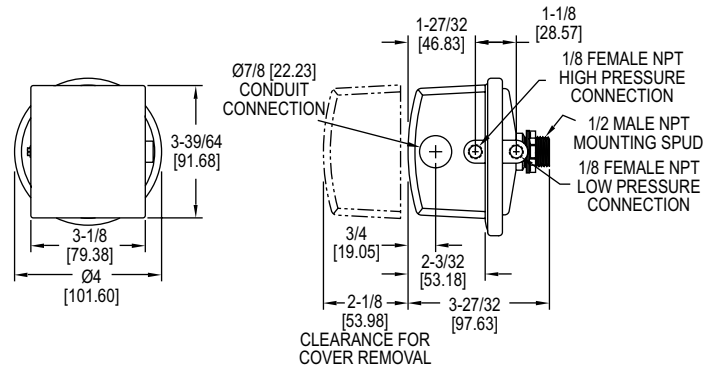

Construction and dimensions. Series 1823 pressure switches.

Uno de nuestros mas populares interruptores de presión. Combina un pequeño tamaño y bajo precio, con una repetibilidad del 2%, exactitud suficiente para las aplicaciones con mas demanda. El ajuste del punto de operación en un extremo, permite instalar el interruptor de un lado en las pared o tablero, permitiendo acceso al tornillo de ajuste.

### Interruptor para Ambiente Húmedo (MIL)

El modelo 1820 puede ser fabricado con un sello especial a prueba de intemperie, o para aplicaciones con alta humedad. Similar al modelo 1823, excepto que la banda de operación es mayor.

Especifique el modelo 1820 (Rango No.) "Mil" en su orden.

MODEL CHART			
Model	Operating Range, in w.c.	Approximate Dead Band	
		At Min. Set Point	At Max. Set Point
1823-00	0.07 to 0.22	0.05	0.05
1823-0	0.15 to 0.5	0.06	0.06
1823-1	0.3 to 1.0	0.08	0.08
1823-2	0.5 to 2.0	0.10	0.12
1823-5	1.5 to 5.0	0.14	0.28
1823-10	2.0 to 10	0.18	0.45
1823-20	3 to 22	0.35	0.70
1823-40	5 to 44	0.56	1.10
1823-80	9 to 85	1.30	3.0

### Especificaciones:

Interruptor de presión diferencial operado por diafragma de 4", para activar un interruptor de presión tipo simple polo doble tiro. El diafragma esta controlado por un resorte calibrado que se puede ajustar para fijar la presión diferencial exacta a la cual el interruptor actuara. El movimiento del diafragma es transmitido al botón del interruptor por un medio mecánico. Interruptor Dwyer Instruments, Inc. Catalogo No. 1823-\_\_\_ para el rango de operación requerido.

### INSTALACIÓN:

1. Seleccione una ubicación libre de vibración excesiva, en donde el agua o aceite no entre al interruptor. Revise encapsulados especiales para aplicaciones especiales.
2. Mientras no se requiera otra, las conexión de presión inferior es recomendada. Monte el interruptor con el diafragma en posición vertical, el interruptor debe recalibrarse para cada cambio de posición.
3. Conecte el interruptor a la fuente de presión diferencial. Tubo metálico con diámetro de 1/4" es recomendado, pero cualquier sistema de tubería que no restrinja el flujo de aire es bueno.
4. Conexiones eléctricas estándar de los interruptores SPDT, común, NA y NC. Los contactos cambian cuando se incrementa la presión del punto de operación.
5. La carga del interruptor no debe exceder los 15 Amp. Especificados. Las capacidades decrecen con altas cargas inductivas y ciclos rápidos de actuación, por lo que en estos casos los limites de corriente deben ser 10 Amp. 0 menores para incrementar la vida del interruptor.

### AJUSTES:

1. Si el interruptor ha sido calibrado en fabrica, revise el punto de operación antes de ponerlo en servicio.
2. De lo contrario, siga los siguientes pasos:
  - A. Para ajustar el punto de operación, gire el tornillo de calibración en sentido de las manecillas del reloj para aumentar el valor y en contra de las manecillas del reloj para disminuir el valor del punto de operación.
  - B. Lo siguiente se recomienda para calibrar o revisar la calibración: Use una T con tres mangueras plásticas, tan pequeñas como sean posible. Conecte una manguera al interruptor de presión, otra al manómetro y por la tercera aplique la presión de esta forma podrá ajustar el interruptor a la presión requerida lo mas exacto posible.

### SPECIFICATIONS

**Service:** Air and non-combustible, compatible gases.  
**Wetted Materials:** Consult factory.  
**Temperature Limits:** -30 to 180°F (-34 to 82.2°C). 1823-00, -20 to 180°F (-28.9 to 82.2°C).  
**Pressure Limits:** 10 psig (68.95 kPa) continuous, 25 psig (172.4 kPa) surge.  
**Switch Type:** Single-pole double-throw (SPDT).  
**Repeatability:** ±2%.  
**Electrical Rating:** 15 A @ 120-480 VAC, 60 Hz. Resistive 1/8 HP @125 VAC, 1/4 HP @ 250 VAC, 60 Hz. De-rate to 10 A for operation at high cycle rates.

**Electrical Connections:** 3 screw type, common, normally open and normally closed.  
**Process Connections:** 1/8" female NPT.  
**Mounting Orientation:** Diaphragm in vertical position. Consult factory for other position orientations.  
**Set Point Adjustment:** Screw type inside mounting spud.  
**Weight:** 1 lb, 5 oz (595 g).  
**Agency Approvals:** CE, UL, CSA, FM.

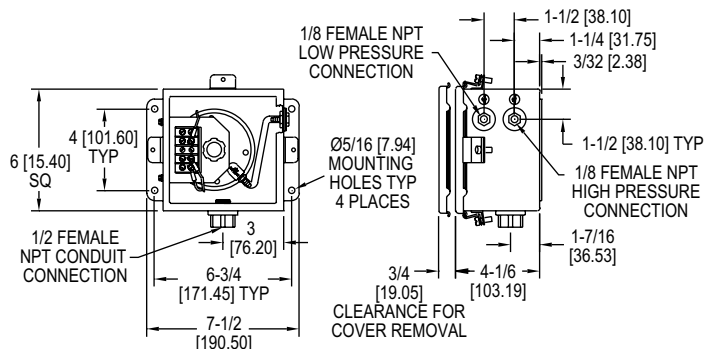

### Encapsulado a Prueba de Intemperie

Encapsulado de acero para condiciones húmedas y/o aceitosas, soporta pruebas de 200 horas de spray salino, pesa 5-1/2 libras. El interruptor debe ser instalado en la planta al momento de su fabricación. Especifique "WP" mas el modelo del interruptor en catalogo.

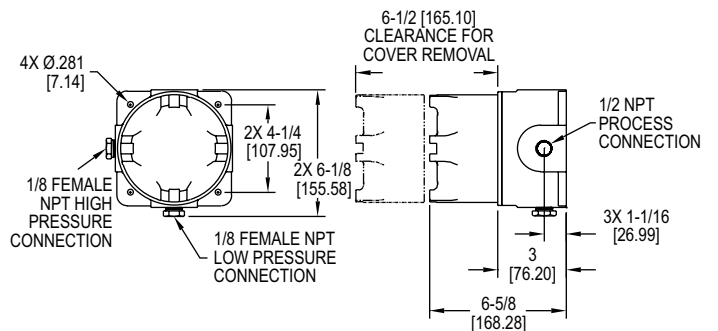

### Encapsulado a Prueba de Explosión

Encapsulado a base de Hierro y Aluminio, pesa aproximadamente 7-1/2 libras. Especifique "EXPL" mas modelo del interruptor en catalogo.